



1 IMPORTANT NOTE

Fixture comes partially assembled.

-  Ensure electrical circuit is disconnected before installation.
-  Luminaires must be installed in accordance with National electrical code and local regulation.

2 CONTINUOUS INSTALLATION

STEP 1
Install the start section as per the previous installation steps.

STEP 2
Each section comes with a pair of 1/4-20 square neck bolts and screws pre-installed on the mounting brackets (one on each side). Remove both fasteners from the mounting bracket (DETAIL-A FIG 6).

STEP 3
Identify the section labeled as "MID".

STEP 4
Align the "MID" section with the previously installed "FIRST" section using the alignment pins provided on the "FIRST" section.

STEP 5
Once aligned and positioned closely together, use the intersectional brackets to join the two sections.

STEP 6
The intersectional bracket assembly is pre-installed on all sections except the "END" section.

STEP 7
After aligning the "MID" section, reposition the bracket assembly by loosening the socket nuts on the extrusion side. Slide the bracket assembly along the mid section so it is centered symmetrically between the two sections.(Final position shown in DETAIL-B)

STEP 8
Once in position, tighten the previously loosened socket nuts to secure the assembly in place.

STEP 9
Then, tighten the socket screw and socket nut connecting the two brackets together (see DETAIL-B).

STEP 10
Reinstall the fasteners removed in step 2 to secure the fixture from the top.

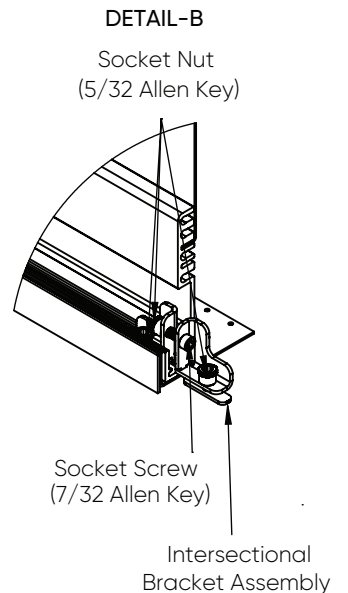
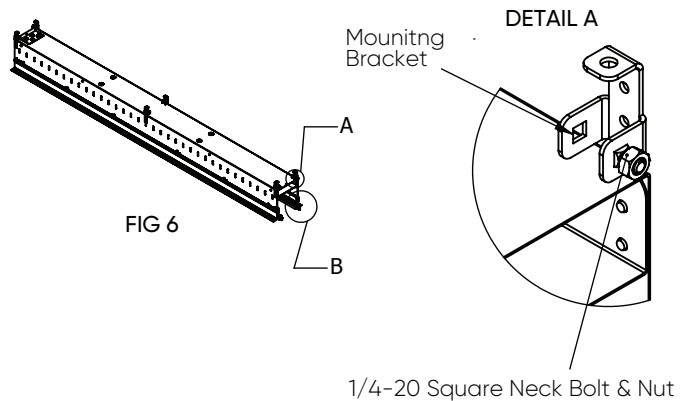

STEP 11

Repeat the process for entire run.

STEP 12

Do not overtighten any fasteners during the installation process.

STEP 13

Once all sections are installed, complete the wiring connections as described in Step 3 on Page 2.

STEP 14

For continuous fixtures, trimless flanges are provided in parts (see FIG-7). Flanges marked with "M" are for mid sections. Flanges marked with "E" are for end sections.

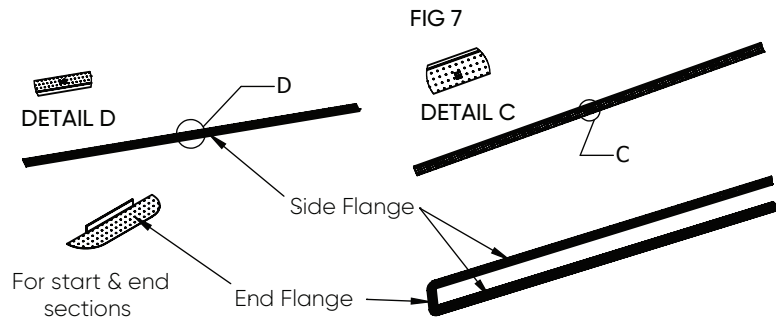

STEP 15

Complete the installation of perforated flanges by following Step 4 on Page 2.